

# Hoshizaki America, Inc.

Dishwasher

Models  
JWE-620UA-6B



“A Superior Degree  
of Reliability”

[www.hoshizaki.com](http://www.hoshizaki.com)

## PARTS LIST



Number: 80VC-3230  
Issued: 6-22-2009  
Revised: 9-18-2012

## Auxiliary Codes

<b>JWE-620UA-6B</b>	U-1	June 2009
	U-2	—
	U-3	August 2009
	V-0	January 2010
	A-0	January 2011
	A-1	May 2011
	B-0	January 2012
	B-1	February 2012
	B-2	April 2012
	B-3	April 2012

### Auxiliary Code Breakdown

The auxiliary code is the first two characters in the serial number. The first character indicates the year. Years progress or regress in alphabetical order. The series runs from "A" through "V" and the letters "I" and "O" are skipped. The second character indicates significant part changes within a year. Base is "0" and this number advances for each change. In cases where there is a letter in parentheses, this designates the month. This is the last character in the serial number. The series runs from "(A)" through "(M)" and the letter "(I)" is skipped. This designation is only included when identifying a parts change within an auxiliary code.

### Note About Ordering Parts

Most assemblies cannot be ordered as complete units; parts in the assemblies generally must be ordered separately.

**MARKS LOCATED UNDER THE AUXILIARY CODE**

- = Part deleted.
- x = Part deleted and replaced by "o" part.
- o = New part in place of "x" part.

**FASTENER PART NUMBER**

**SCREWS**

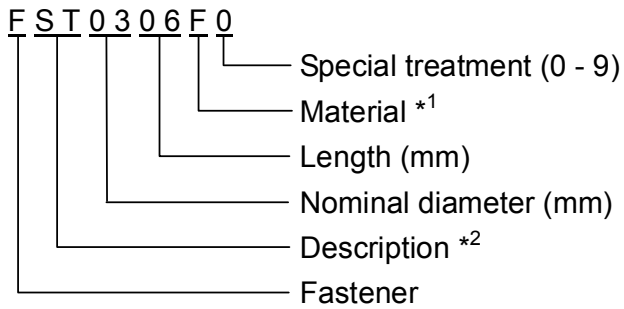

\*1 Material

- F: Steel
- S: Austenitic stainless steel
- M: Martensitic stainless steel
- B: Copper alloy
- P: Polycarbonate
- N: Polyamide
- V: PVC
- A: ABS
- X: Polyacetal
- L: Aluminum

**NUTS & WASHERS**

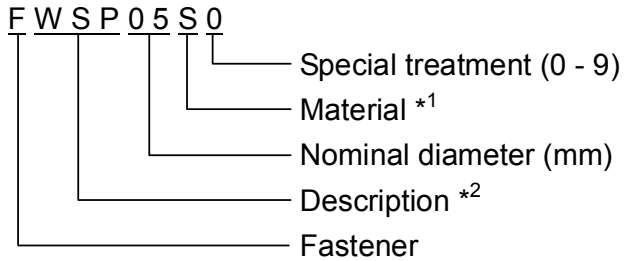

\*2 Description

- First letter
- S: Machine screw
- T: Tapping screw
- M: Wood screw
- B: Bolt
- W: Washer
- N: Nut

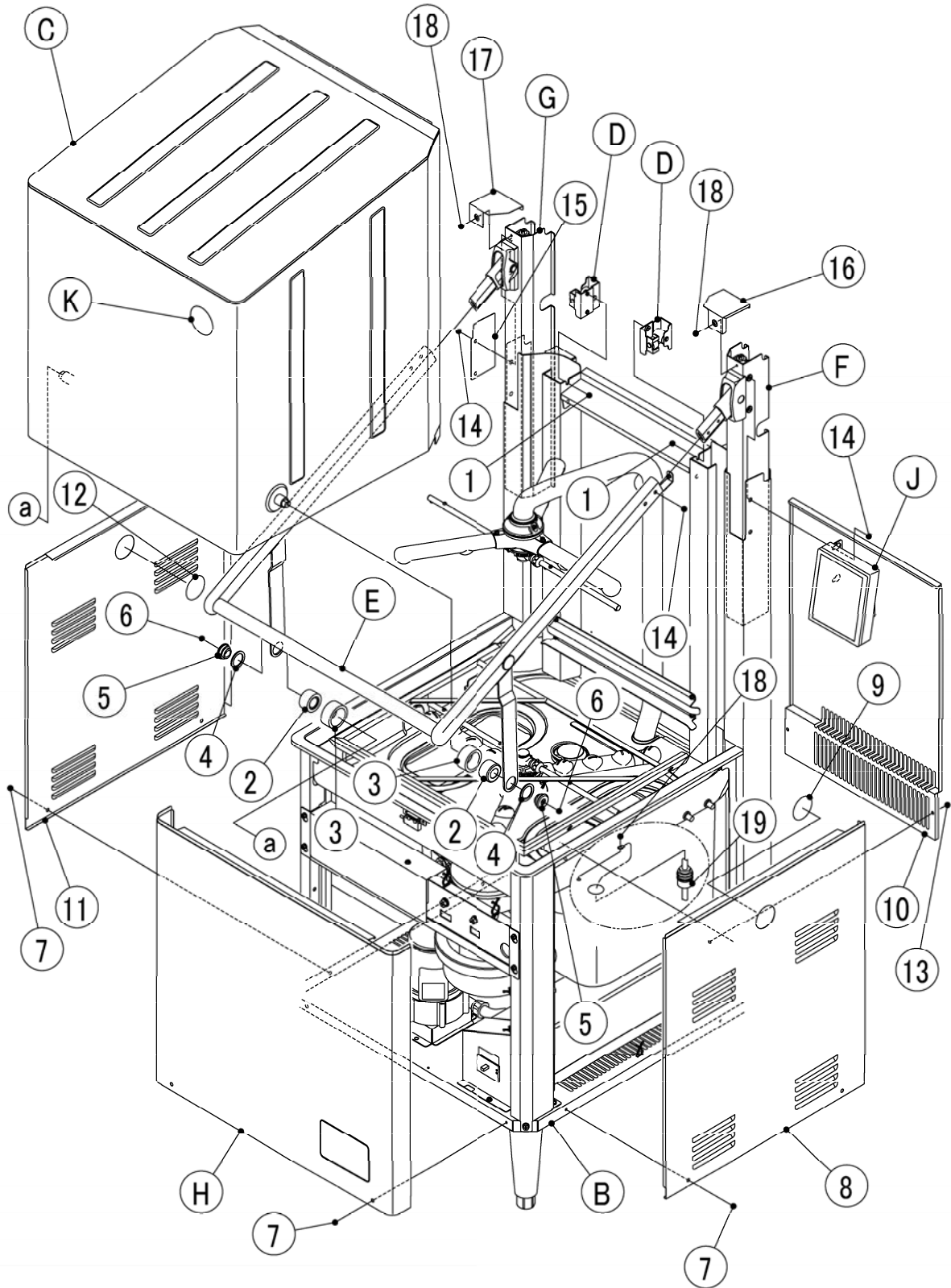

HA

MODEL : JWE-620UA-6B		TITLE : A. DISHWASHER ASSY					
INDEX NO.	DESCRIPTION	MATERIAL OR MODEL NUMBER	PART NUMBER	REQ'D NUMBER			
				U-1,U-2 U-3,V-0 A-0	A-1,B-0 B-1	B-2	B-3
B	TANK ASSY	-	1H3307011	1	1	1	1
C	DOOR ASSY	-	2H8149A02	1	1	1	1
D	ROLLER UNIT	-	4Y3172A01	2	2	2	2
E	HANDLE ASSY	-	3Y0438A02	1	1	1	1
F	SPRING UNIT (R)	-	2H7218A02	1	1	1	1
G	SPRING UNIT (L)	-	2H7219A02	1	1	1	1
H	FRONT PANEL ASSY	-	3Y4248A01	1	1	1	1
J	OPERATION PANEL ASSY	-	2H9026A01	1	1	1	1
K	LABEL LOCATION	-	1H4360A01	1	1	1	1
S	ACCESSORIES	-	A01541-01	-			
1	HEX HEAD BOLT W/ WASHERS	S.S	FBK0512S1	4	4	4	4
2	COLLAR (B) - HANDLE	PA	4X5052-01	2	2	2	2
3	HOSE (A)	EPDM	4Y3169-01	2	2	2	2
4	COLLAR (A) - HANDLE	PA	4X5051-01	2	2	2	2
5	CAP - SHAFT (B)	S.S	4Y3170-01	2	2	2	2
6	HEX HEAD BOLT W/ WASHERS	S.S	FBK0412S1	2	2	2	2
7	TRUSS HEAD MACHINE SCREW	S.S	FST0508S0	6	6	6	6
8	SIDE PANEL (R)	S.S (3Y2344A02)	2H7593-02	1	1	1	1
9	PLATE		4Y4243M01	1	1	1	1
10	REAR PANEL	S.S	2H9407M02	1	1	1	1
11	SIDE PANEL (L)	S.S (3Y2345A02)	2H7594-02	1	1	1	1
12	PLATE		4Y4243M01	1	1	1	1
13	FLANGE BOLT (C-TITE)	S.S	FTR0408M0	4	4	4	4
14	HEX HEAD BOLT W/ WASHERS	S.S	FBK0612S1	8	8	8	8
15	COVER - OP	S.S	4Y3167-01	1	1	1	1
16	COVER (R) - FRAME	S.S	4Y3166-01	1	1	1	1
17	COVER (L) - FRAME	S.S	4Y3168-01	1	1	1	1

### B. TANK ASSY (1/2)

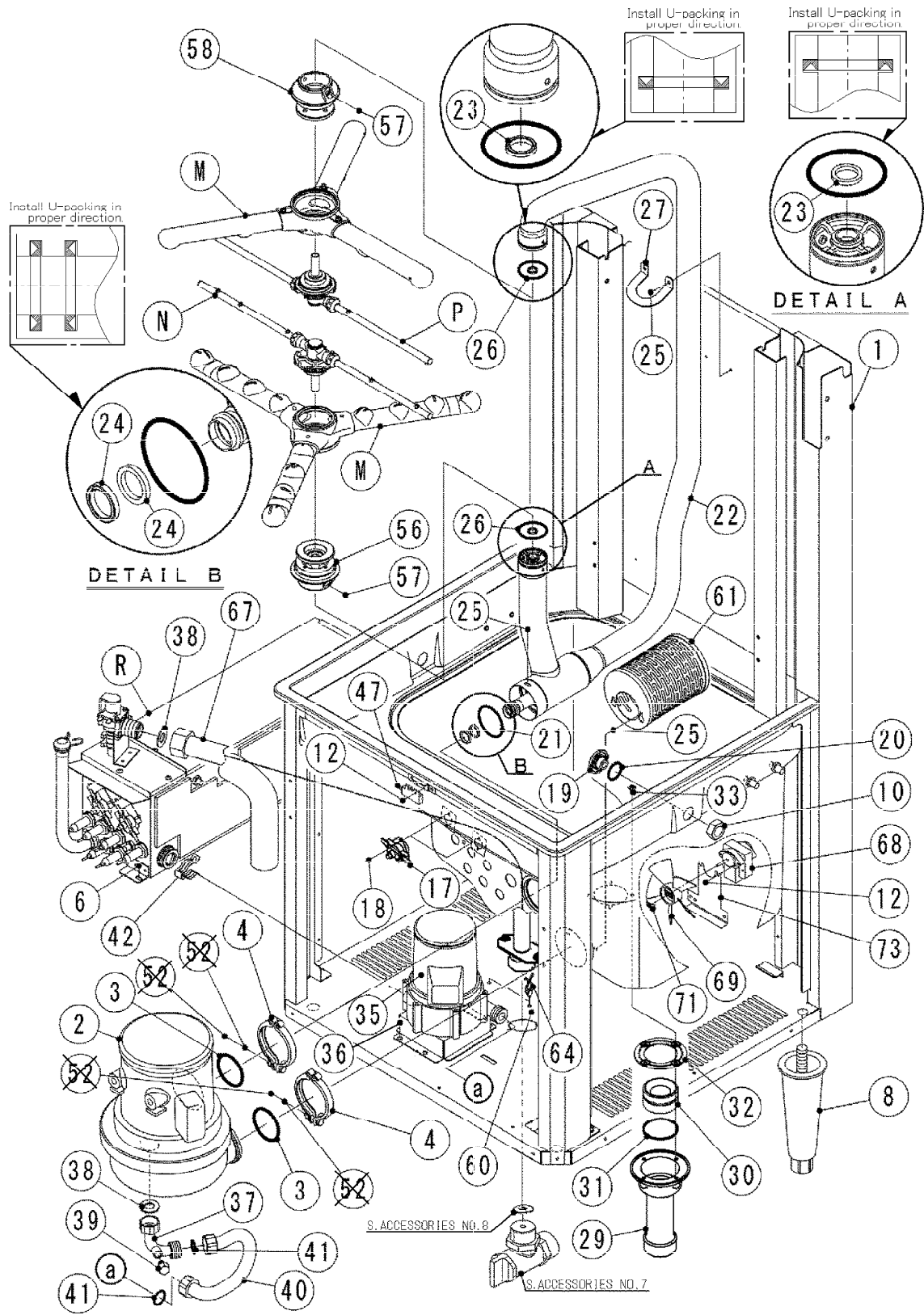

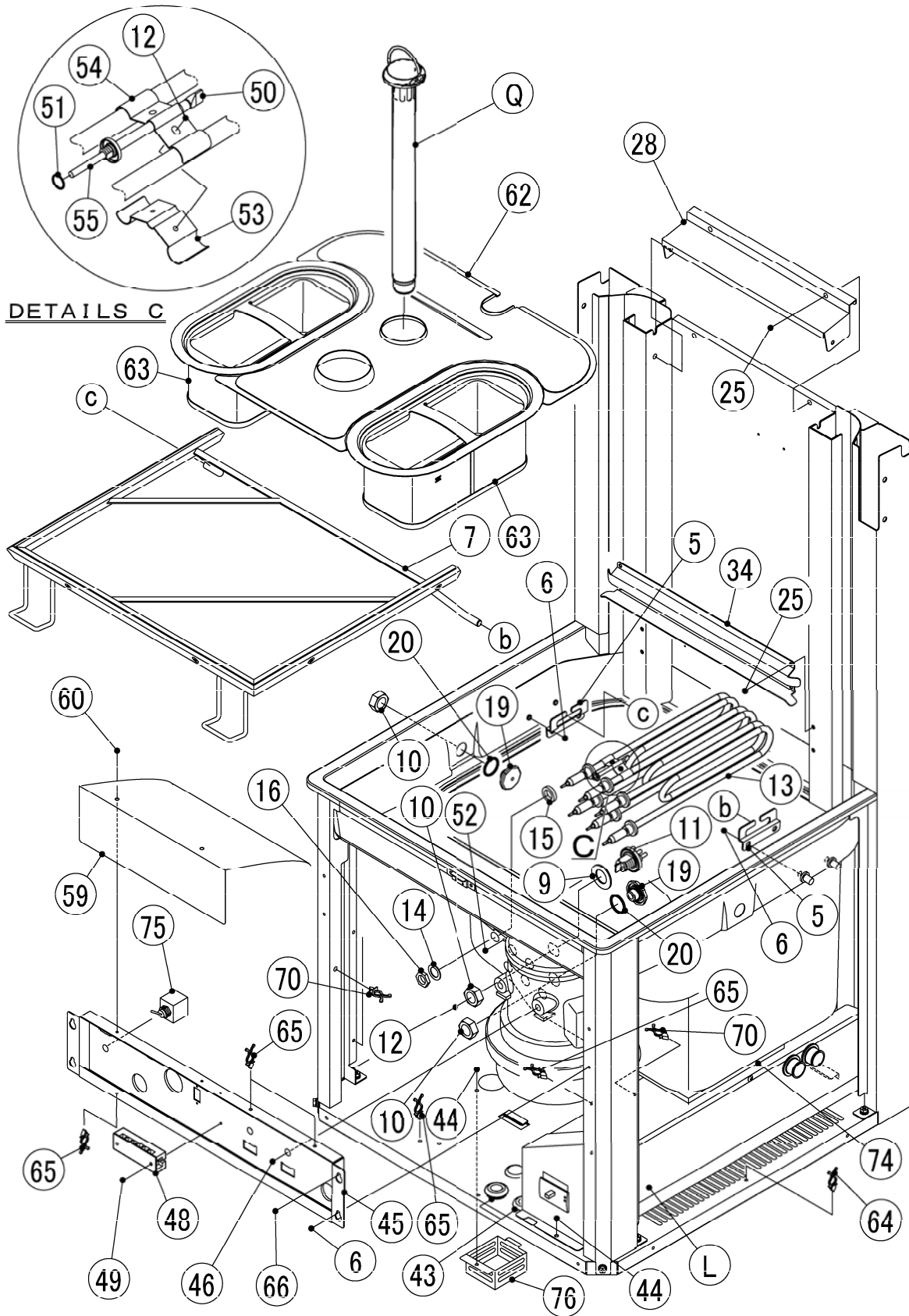

HA

MODEL : JWE-620UA-6B		TITLE : B. TANK ASSY					
INDEX NO.	DESCRIPTION	MATERIAL OR MODEL NUMBER	PART NUMBER	REQ'D NUMBER			
				U-1,U-2 U-3,V-0 A-0	A-1,B-0 B-1	B-2	B-3
L	CONTROL BOX ASSY	-	2H9022A01	1	1	1	1
M	SPRAY ARM ASSY	-	3Y3561A01	2	2	2	2
N	RINSE SPRAY ARM (LO) ASSY	-	3Y6791A02	1	1	-	-
		-	3Y2447A02	-	-	1	1
P	RINSE SPRAY ARM (UP) ASSY	-	3Y6790A02	1	1	-	-
		-	3Y2448A02	-	-	1	1
Q	OVERFLOW PIPE ASSY	-	3Y6605A01	1	1	1	1
R	RINSE TANK ASSY	-	1H4554A01	1	1	1	1
1	FLUSH TANK	S.S	1H4444G02	1	1	1	1
2	PUMP MOTOR	50LPS- 3756HUL(60Hz)	P01548-01	1	1	1	1
3	O-RING	EPDM G60	4Y3158F01	2	2	2	2
4	BAND - PUMP	S.S	4Y7714A02	2	2	2	2
5	BRACKET - RACK RAIL	S.S	4Y3171-01	2	2	2	2
6	HEX HEAD BOLT W/ WASHERS	S.S	FBK0512S1	7	7	7	7
7	RACK RAIL - WELD	S.S	2H7206G01	1	1	1	1
8	ADJUSTABLE LEG	SD-240HF-D	P01591-01	4	4	4	4
9	PACKING (B) - SENSOR	SI.R	4X5112-01	1	1	1	1
10	NUT	Exchange with No.19	4Y3670-01	4	4	4	4
11	LEVEL SENSOR	PPS, S.S	3X4140G01	1	1	1	1
12	PAN HEAD MACHINE SCREW W/ WASHERS	S.S	FSK0308S0	8	8	8	8
13	SHEATH HEATER	-	P00550-01	3	3	3	3
14	WASHER	S.S	P00550F01	6	6	6	6
15	PACKING	SI.R	P00550F02	6	6	6	6
16	NUT	S.S	P00550F03	6	6	6	6
17	THERMOSTAT	OFF95°C±3K OPEN	4Y1929-02	2	2	2	2
18	PAN HEAD MACHINE SCREW W/ WASHERS	S.S	FSK0408S0	4	4	4	4
19	CAP	Exchange with No.10	4Y3177-01	3	3	3	3
20	O-RING	EPDM G25	7614-G025	3	3	3	3
21	O-RING	NBR G55	7611-G055	1	1	1	1
22	FLUSH PIPE	S.S	1H3306G02	1	1	1	1
23	U-PACKING	EPDM	4Y3371-01	2	2	2	2
24	U-PACKING	EPDM	4Y3371-02	2	2	2	2
25	HEX HEAD BOLT W/ WASHERS	S.S	FBK0408S1	13	13	13	13
26	O-RING	NBR S42	7611-S042	2	2	2	2



HA

MODEL : JWE-620UA-6B		TITLE : B. TANK ASSY					
INDEX NO.	DESCRIPTION	MATERIAL OR MODEL NUMBER	PART NUMBER	REQ'D NUMBER			
				U-1,U-2 U-3,V-0 A-0	A-1,B-0 B-1	B-2	B-3
27	BRACKET - PIPE UNIT	S.S	4Y3174-01	1	1	1	1
28	WATER GUARD	S.S	4Y3175-01	1	1	1	1
29	DRAIN PIPE	S.S	3Y4170M01	1	1	1	1
30	JOINT - OVERFLOW	PE	4Y3176-01	1	1	1	1
31	O-RING	NBR G50	7611-G050	1	1	1	1
32	PACKING - JOINT	EPDM	4Y3165-01	1	1	1	1
33	SCREW	S.S	4Y1319-06	4	4	4	4
34	RACK GUIDE - REAR	S.S	3Y0440-01	1	1	1	1
35	PUMP MOTOR	PMD-1023BHZ3(60Hz)	P00995-01	1	1	1	1
36	HEX HEAD BOLT W/ WASHERS	S.S	FBK0612S1	1	1	1	1
37	JOINT - PIPE	S.S	4Y3179G01	1	1	1	1
38	PACKING - TUBE	FLUORORUBBER	4H9792-01	2	2	2	2
39	RINSE PLUG	C3604	4X8858-01	1	1	1	1
40	FLEXIBLE PIPE	S.S	442363-12	1	1	1	1
41	PACKING	FLUORORUBBER	442363F01	2	2	2	2
42	QUICK FASTENER	16B-R3	456912-07	1	1	1	1
43	GROMMET	EPDM	410666-05	2	2	2	2
44	FLANGE BOLT (C-TITE)	S.S	FTR0408M0	2	2	2	2
45	SUPPORT - WASHING PUMP	S.S	2H9530M01	1	1	1	1
46	HEX HEAD BOLT W/ WASHERS	S.S	FBK1016S0	2	2	2	2
47	REED SWITCH	PS-0074-501	453861-01	1	1	1	1
48	TERMINAL BLOCK	T3052-1-6P-CS	P01375-04	1	1	1	1
49	TRUSS HEAD MACHINE SCREW	S.S	FST0412S0	2	2	2	2
50	THERMISTOR PIPE - WELD	S.S	4Y3183G01	1	1	1	1
51	O-RING	EPDM P7	7614-P007	1	1	1	1
52	NUT	S.S	FNH106S0	1	1	1	1
53	THERMOSTAT PLATE (LO)	S.S	4Y3163-01	1	1	1	1
54	THERMOSTAT PLATE (UP)	S.S	4Y3164-01	1	1	1	1
55	THERMISTOR (A) - ASSY	-	449758-02	1	1	1	1
56	HEADER (LO)	PPS, S.S	4Y5305A01	1	1	1	1
57	HEX HEAD BOLT W/ WASHERS	SS	FBK0412S1	6	6	6	6



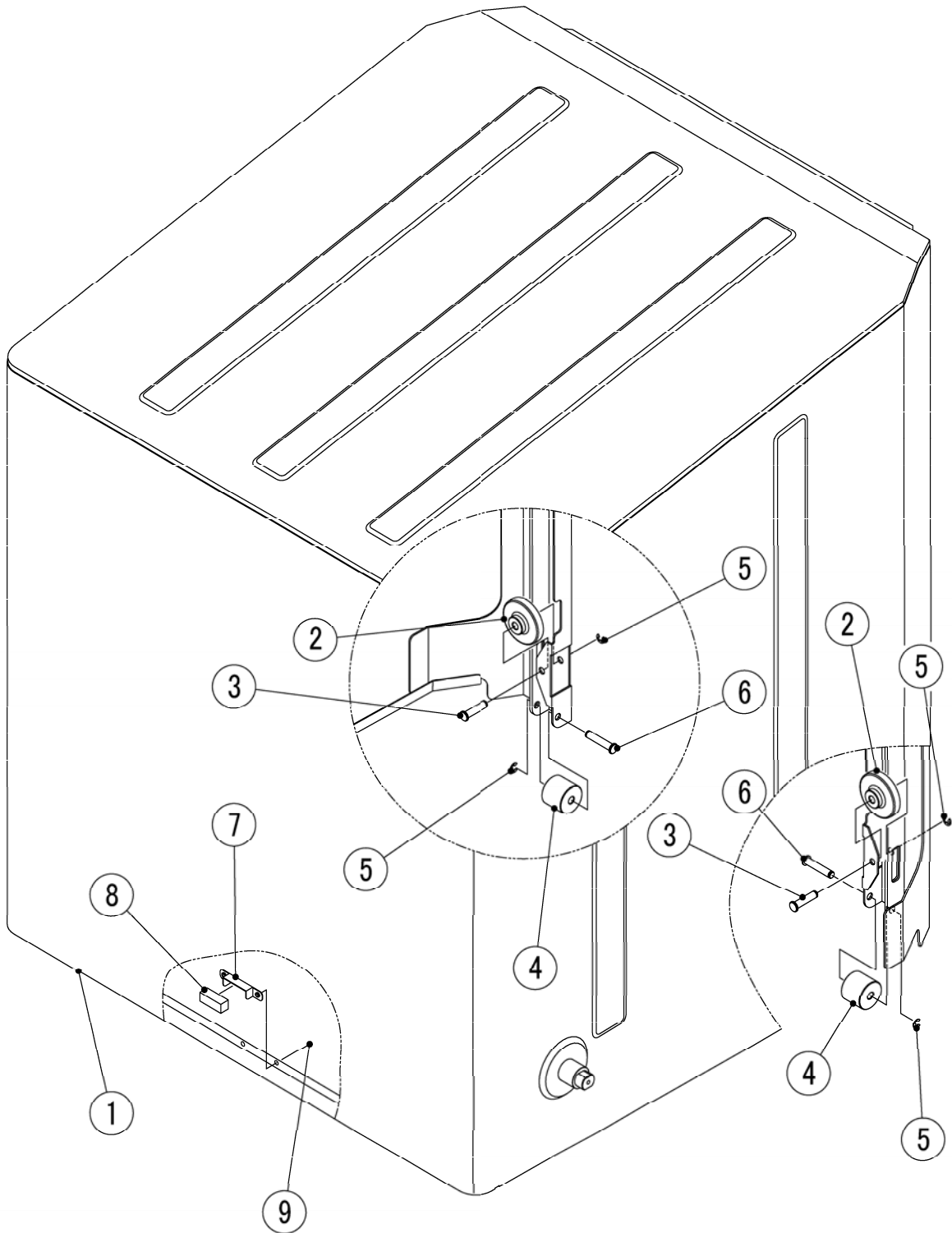

HA

MODEL : <b>JWE-620UA-6B</b>		TITLE : <b>C. DOOR ASSY</b>					
INDEX NO.	DESCRIPTION	MATERIAL OR MODEL NUMBER	PART NUMBER	REQ'D NUMBER			
				U-1,U-2 U-3,V-0 A-0	A-1,B-0 B-1	B-2	B-3
1	DOOR - WELD	S.S	2H8150G02	1	1	1	1
2	DOOR ROLLER (A)	PE	4Y3219-01	2	2	2	2
3	SHAFT (A) - ROLLER (LO)	S.S	4Y3220-01	2	2	2	2
4	DOOR ROLLER (B)	PE	4Y3221-01	2	2	2	2
5	E-RING	S.S	721S-0004	4	4	4	4
6	SHAFT (B) - ROLLER (LO)	S.S	4Y3222-01	2	2	2	2
7	MAGNET BRACKET	S.S	4X5130-01	1	1	1	1
8	MAGNET	TG-0279	440805-01	1	1	1	1
9	SCREW - PAN HEAD	S.S	4Y4752M01	2	2	2	2

D. ROLLER UNIT

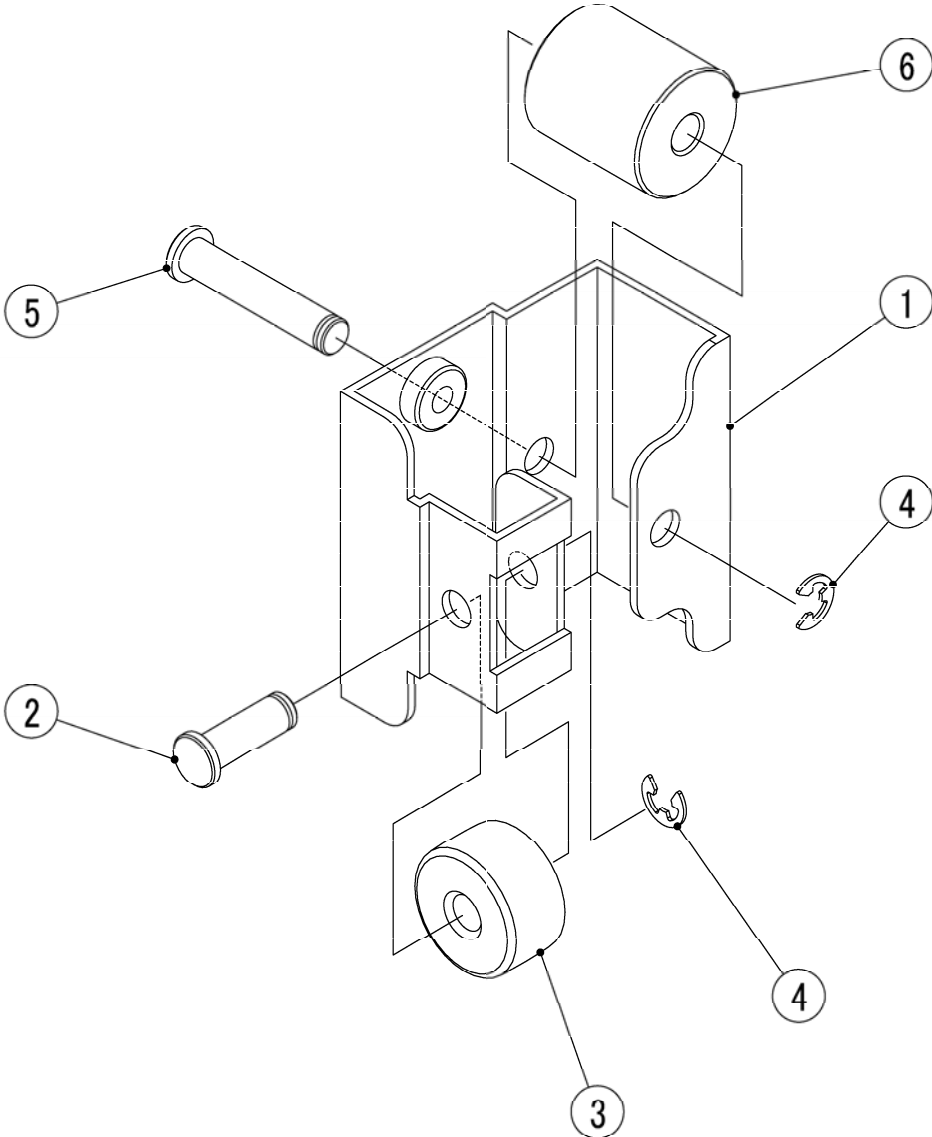

HA

MODEL : <b>JWE-620UA-6B</b>		TITLE : <b>D. ROLLER UNIT</b>					
INDEX NO.	DESCRIPTION	MATERIAL OR MODEL NUMBER	PART NUMBER	REQ'D NUMBER			
				U-1,U-2 U-3,V-0 A-0	A-1,B-0 B-1	B-2	B-3
1	ROLLER BRACKET - WELD	S.S	4Y3188G01	1	1	1	1
2	SHAFT (B) - ROLLER (UP)	S.S	4Y3187-01	1	1	1	1
3	ROLLER (B) - UP	PE	4Y3303-01	1	1	1	1
4	E-RING	S.S	721S-0004	2	2	2	2
5	SHAFT (A) - ROLLER (UP)	S.S	4Y3301-01	1	1	1	1
6	ROLLER (A) - UP	PE	4Y3302-01	1	1	1	1

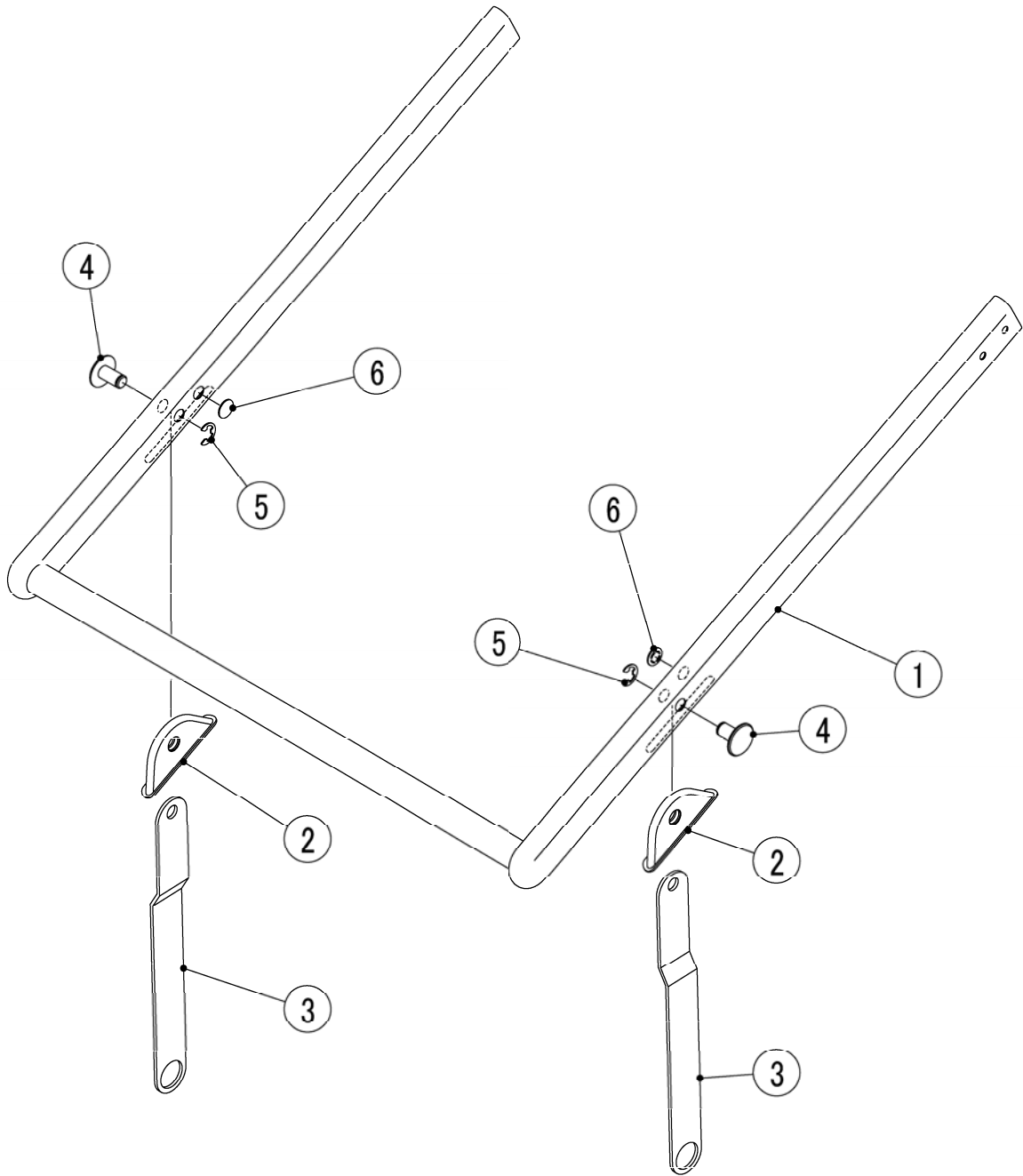

HA

MODEL : <b>JWE-620UA-6B</b>		TITLE : <b>E. HANDLE ASSY</b>					
INDEX NO.	DESCRIPTION	MATERIAL OR MODEL NUMBER	PART NUMBER	REQ'D NUMBER			
				U-1,U-2 U-3,V-0 A-0	A-1,B-0 B-1	B-2	B-3
1	HANDLE - WELD	S.S	3Y0406G02	1	1	1	1
2	CAP - HANDLE	PA	3X1101-01	2	2	2	2
3	LINK - HANDLE	S.S	4Y6026M01	2	2	2	2
4	SHAFT (C) - LINK	S.S	4X5049-01	2	2	2	2
5	E-RING	S.S	721S-0010	2	2	2	2
6	BUSH - HANDLE	PE	4Y3563-01	2	2	2	2



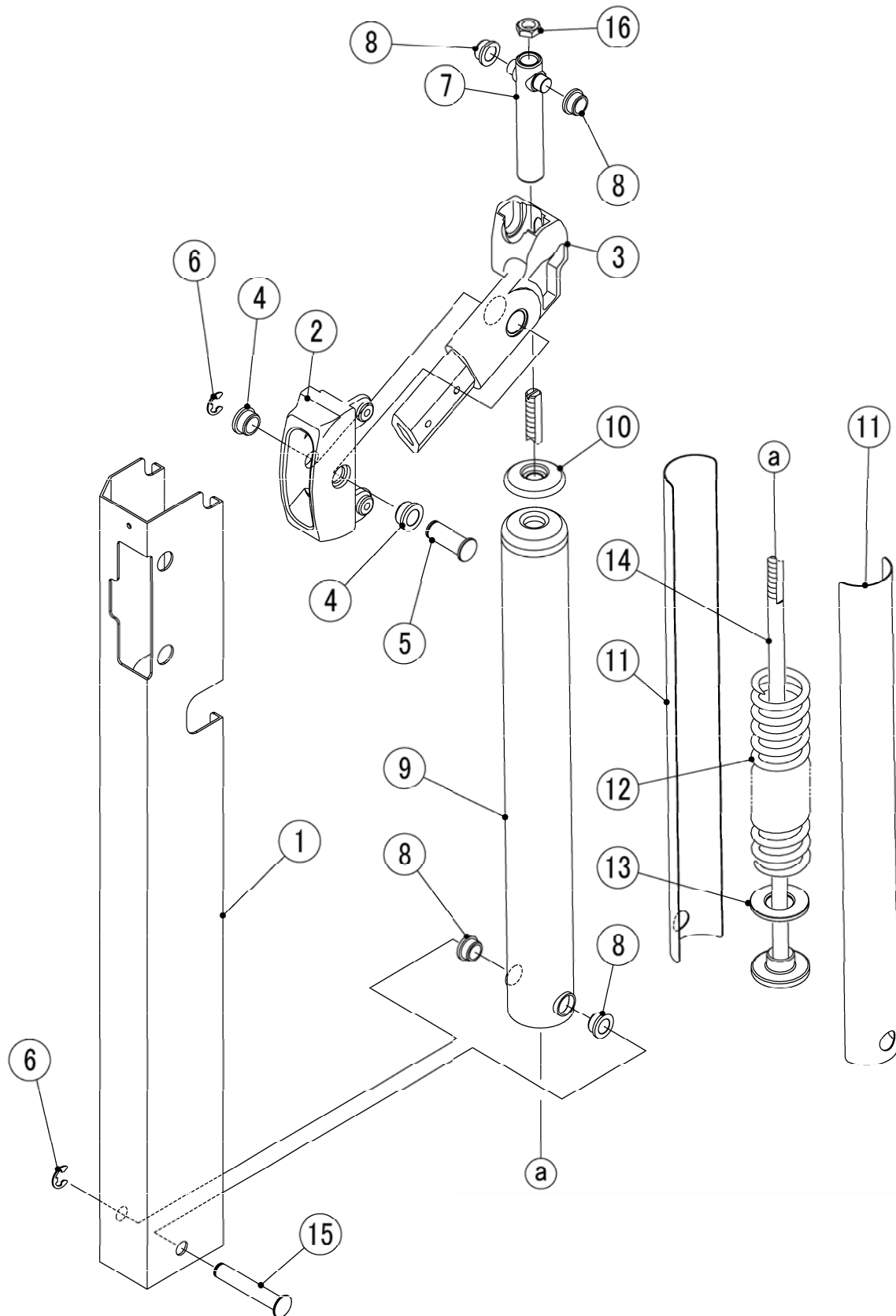

**HA**

MODEL : <b>JWE-620UA-6B</b>		TITLE : <b>F. SPRING UNIT (R)</b>					
INDEX NO.	DESCRIPTION	MATERIAL OR MODEL NUMBER	PART NUMBER	REQ'D NUMBER			
				U-1,U-2 U-3,V-0 A-0	A-1,B-0 B-1	B-2	B-3
1	SPRING FRAME (R)	S.S	3Y0460-01	1	1	1	1
2	ARM HOLDER	S.S	2H7237-01	1	1	1	1
3	ARM (R)	S.S	2H7238-01	1	1	1	1
4	SLEEVE BEARING	PPS	4Y3237-02	2	2	2	2
5	ARM SHAFT	S.S	4Y3228-01	1	1	1	1
6	E-RING	S.S	721S-0008	2	2	2	2
7	SPRING ADJUSTER	S.S	4Y3229-01	1	1	1	1
8	SLEEVE BEARING	PPS	4Y3237-01	4	4	4	4
9	SPRING PIPE	S.S	3Y0425G01	1	1	1	1
10	COLLAR (UP) - SPRING	PE	4Y3230-01	1	1	1	1
11	GUIDE PIPE - SPRING	PE	3Y0461-01	2	2	2	2
12	SPRING	-	3Y4353M01	1	1	1	1
13	COLLAR (LO) - SPRING	PE	4Y3231-01	1	1	1	1
14	SPRING ROD - WELD	S.S	4Y3238G01	1	1	1	1
15	SHAFT - SPRING PIPE	S.S	4Y3233-01	1	1	1	1
16	U-NUT	S.S	FNU110S0	1	1	1	1

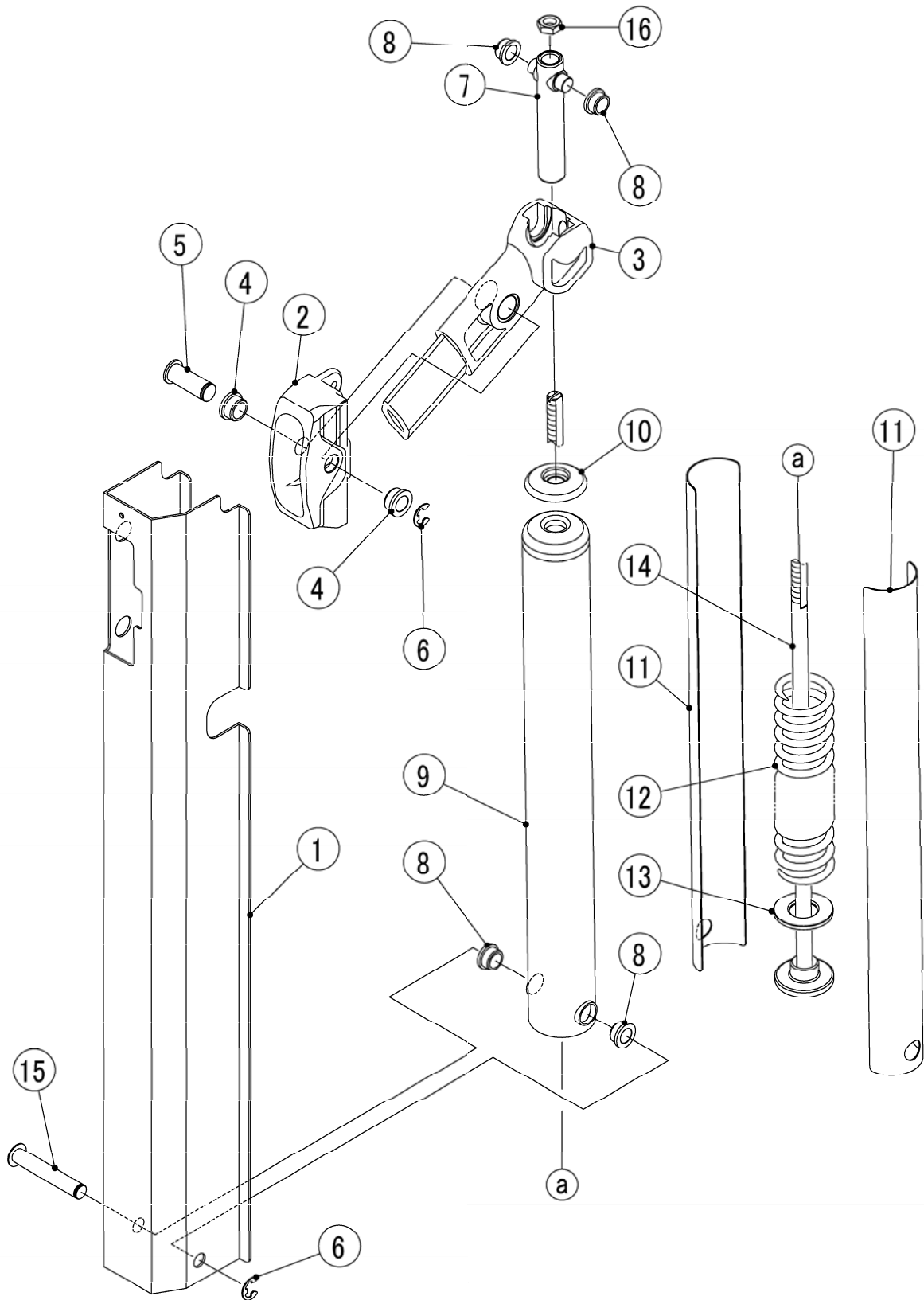

**HA**

MODEL : <b>JWE-620UA-6B</b>		TITLE : <b>G. SPRING UNIT (L)</b>					
INDEX NO.	DESCRIPTION	MATERIAL OR MODEL NUMBER	PART NUMBER	REQ'D NUMBER			
				U-1,U-2 U-3,V-0 A-0	A-1,B-0 B-1	B-2	B-3
1	SPRING FRAME (L)	S.S	3Y0463-01	1	1	1	1
2	ARM HOLDER	S.S	2H7237-01	1	1	1	1
3	ARM (L)	S.S	2H7239-01	1	1	1	1
4	SLEEVE BEARING	PPS	4Y3237-02	2	2	2	2
5	ARM SHAFT	S.S	4Y3228-01	1	1	1	1
6	E-RING	S.S	721S-0008	2	2	2	2
7	SPRING ADJUSTER	S.S	4Y3229-01	1	1	1	1
8	SLEEVE BEARING	PPS	4Y3237-01	4	4	4	4
9	SPRING PIPE	S.S	3Y0425G01	1	1	1	1
10	COLLAR (UP) - SPRING	PE	4Y3230-01	1	1	1	1
11	GUIDE PIPE - SPRING	PE	3Y0461-01	2	2	2	2
12	SPRING	-	3Y4353M01	1	1	1	1
13	COLLAR (LO) - SPRING	PE	4Y3231-01	1	1	1	1
14	SPRING ROD - WELD	S.S	4Y3238G01	1	1	1	1
15	SHAFT - SPRING PIPE	S.S	4Y3233-01	1	1	1	1
16	U-NUT	S.S	FNU110S0	1	1	1	1

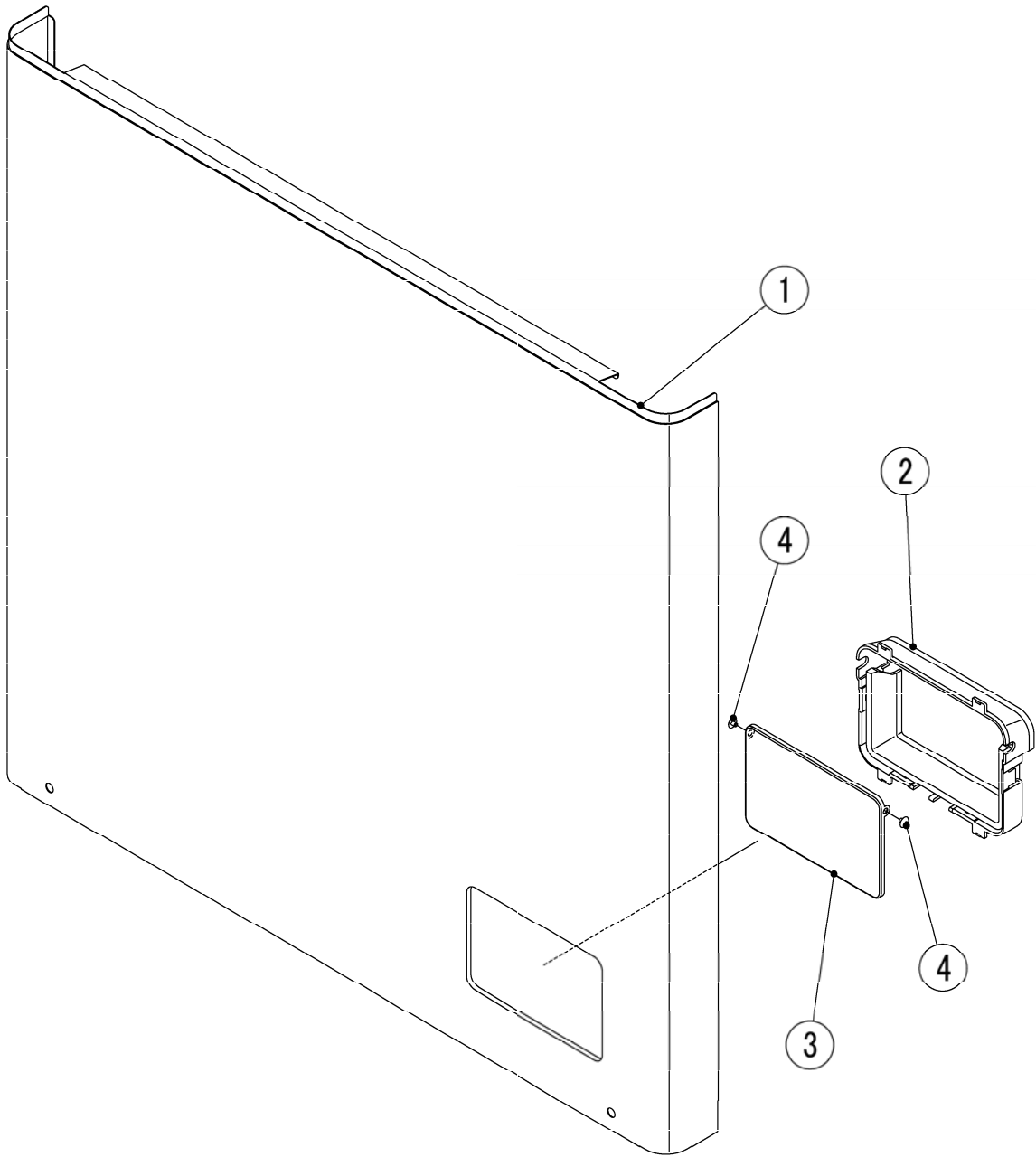

**HA**

MODEL : JWE-620UA-6B		TITLE : H. FRONT PANEL ASSY					
INDEX NO.	DESCRIPTION	MATERIAL OR MODEL NUMBER	PART NUMBER	REQ'D NUMBER			
				U-1,U-2 U-3,V-0 A-0	A-1,B-0 B-1	B-2	B-3
1	FRONT PANEL - WELD	S.S	3Y4243G01	1	1	1	1
2	GUIDE FRAME	ABS	114731-02	1	1	1	1
3	COVER - GFCI	S.S	3Y0753-01	1	1	1	1
4	PUSH RIVET	PA	411399-07	2	2	2	2

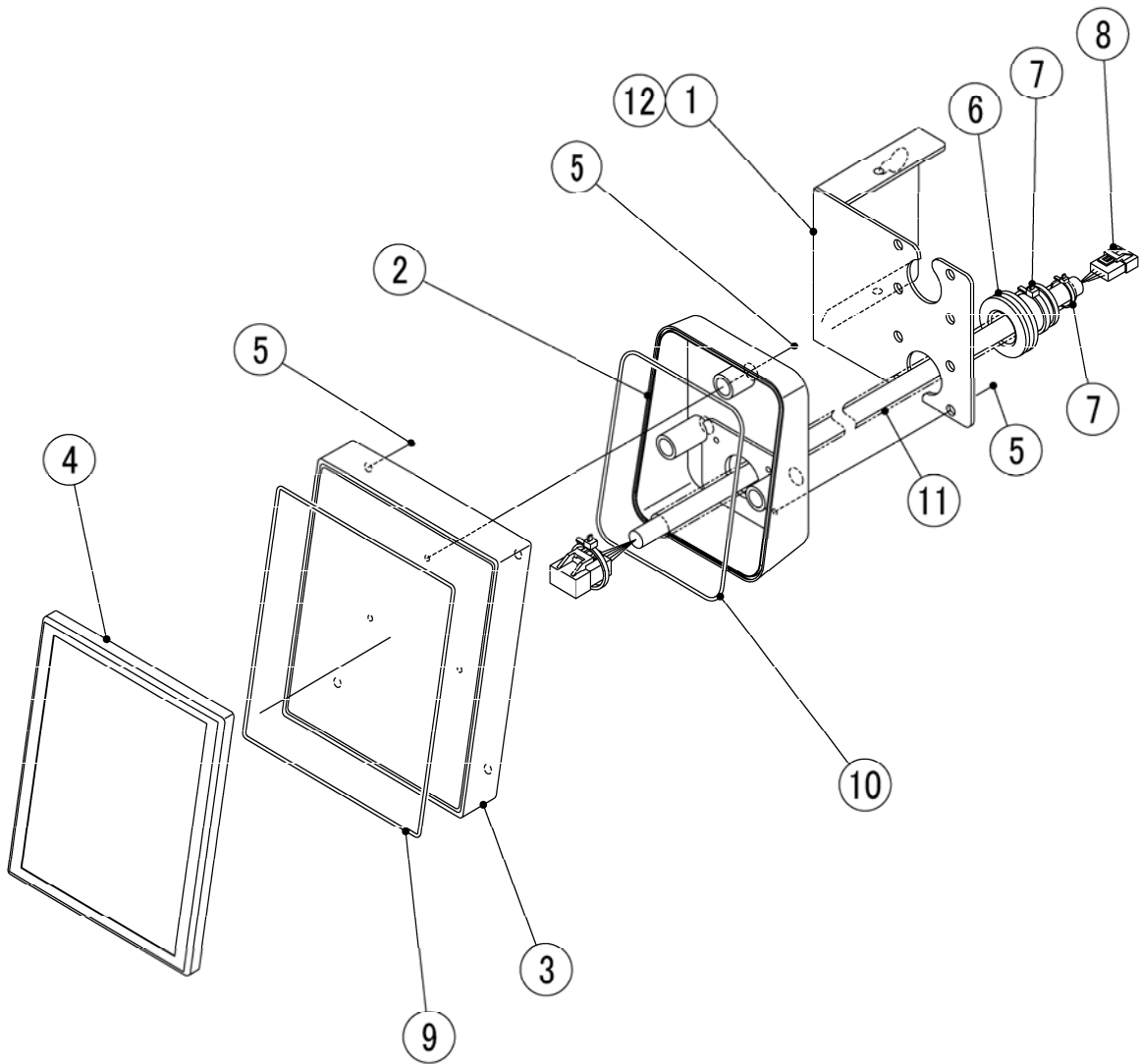

HA

MODEL : <b>JWE-620UA-6B</b>		TITLE : <b>J. OPERATION PANEL ASSY</b>					
INDEX NO.	DESCRIPTION	MATERIAL OR MODEL NUMBER	PART NUMBER	REQ'D NUMBER			
				U-1,U-2 U-3,V-0 A-0	A-1,B-0 B-1	B-2	B-3
1	STAY - OP	S.S	4Y3227-01	1	1	1	1
2	JOINT - OPERATION (B)	ABS	2H4683-01	1	1	1	1
3	OPERATION BOARD	-	P00999-01	1	1	1	1
4	OPERATION PANEL (B)	ABS	1H4359P01	1	1	1	1
5	TRUSS HEAD TAPPING SCREW	S.S	FT20412M0	11	11	11	11
6	GROMMET	NBR	4H2568-01	1	1	1	1
7	CABLE TIE	PA, CV-100	7920-0002	2	2	2	2
8	CABLE - OPERATION	-	3X4524A12	1	1	1	1
9	TUBE (A)	SI.R(W) φ1.6×0.8 L=540	2H7225-09	1	1	1	1
10	TUBE (B)	SI.R, φ2.0×1.2 L=345	2H7225-10	1	1	1	1
11	VINYL TUBE - UL	PVC, L=500 79503B12K	2H7225-11	1	1	1	1
12	CABLE TIE	PA, CV-150A	7920-0021	1	1	1	1



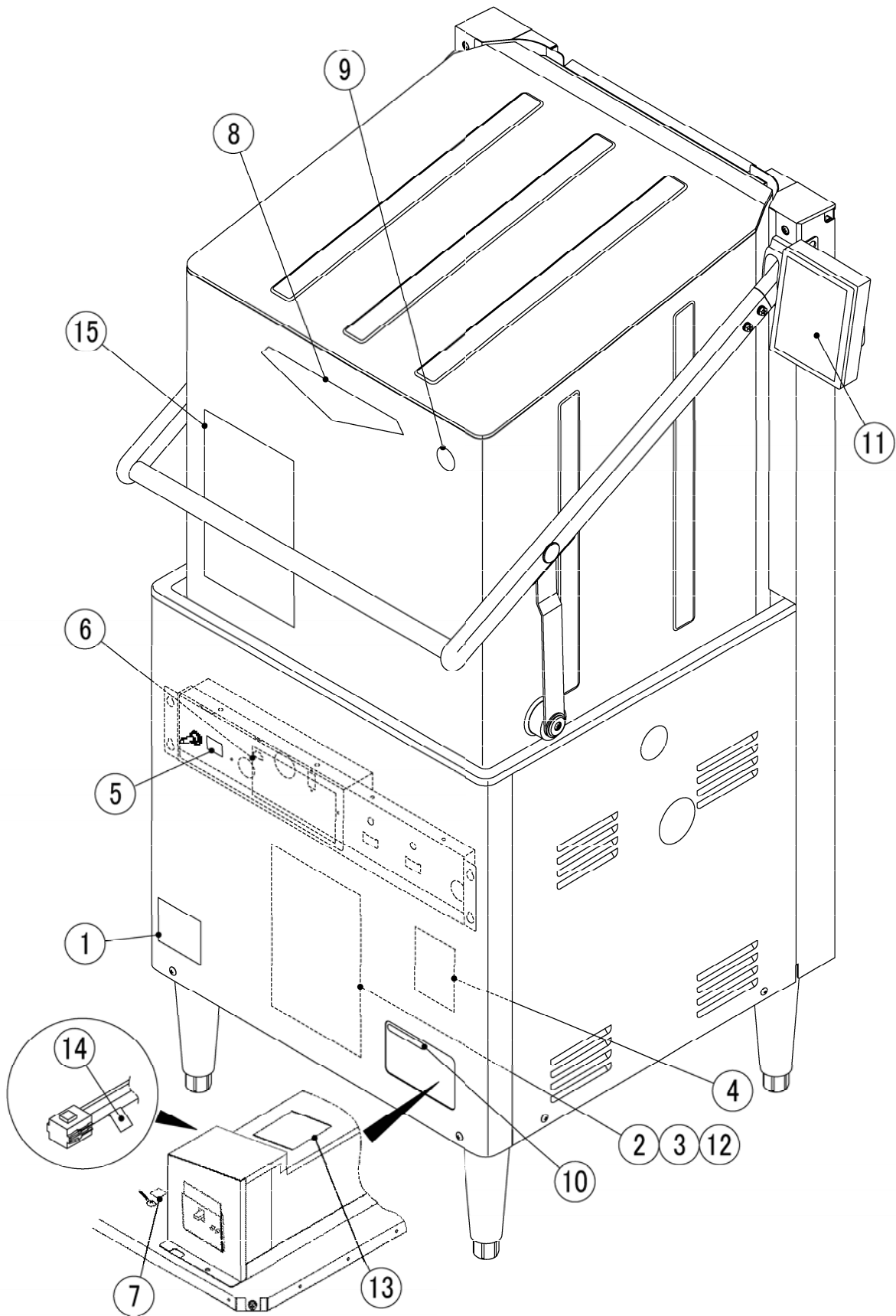

## HA

MODEL : <b>JWE-620UA-6B</b>				TITLE : <b>K. LABEL LOCATION</b>			
INDEX NO.	DESCRIPTION	MATERIAL OR MODEL NUMBER	PART NUMBER	REQ'D NUMBER			
				U-1,U-2 U-3,V-0 A-0	A-1,B-0 B-1	B-2	B-3
1	NAMEPLATE	PES	N/A	1	1	1	1
2	WIRING LABEL	-	2H9031L01	1	1	1	1
3	LABEL - CONTROLLER	-	255627L01	1	1	1	1
4	WARNING LABEL - SERVICE	-	472727L01	1	1	1	1
5	LABEL - VOLTAGE TAP	-	474063L01	1	1	1	1
6	LABEL - CONNECTION	-	371420L01	1	1	1	1
7	LABEL - GROUNDING (B)	PES	450452-02	1	1	1	1
8	LOGO LABEL	PES	365553-04	1	1	1	1
9	LABEL - PENGUIN	PES	453783-01	1	1	1	1
10	LABEL - GFCI	PES	472728L01	1	1	1	1
11	OPERATION LABEL	PES	371419L01	1	1	1	1
12	VINYL CASE	PE	4X0420-01	1	1	1	1
13	LABEL - WIRING	-	4Y5295L01	1	1	1	1
14	LABEL - PLUG	-	422730-01	1	1	1	1
15	MAINTENANCE LABEL	PES	371421L01	1	1	1	1

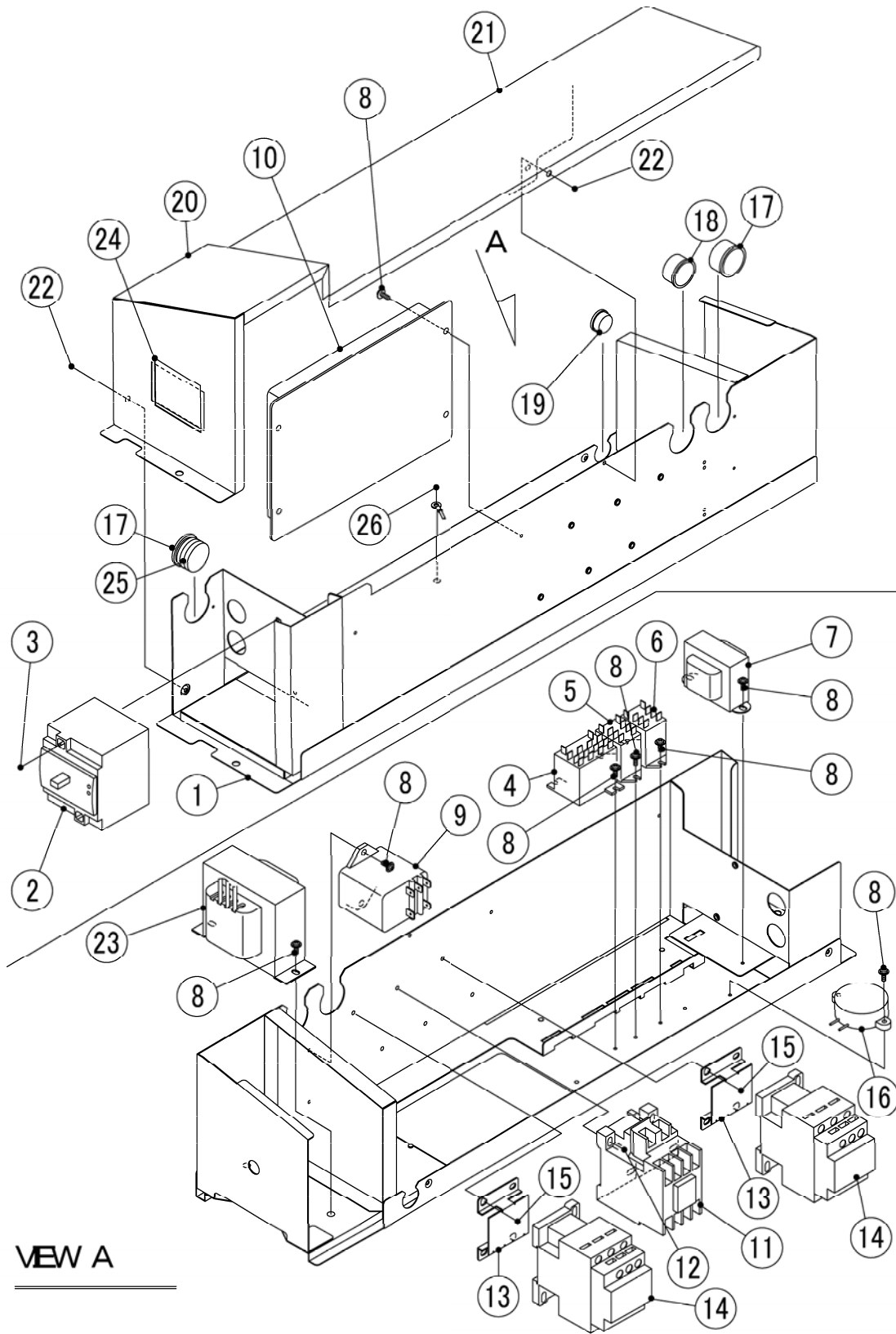

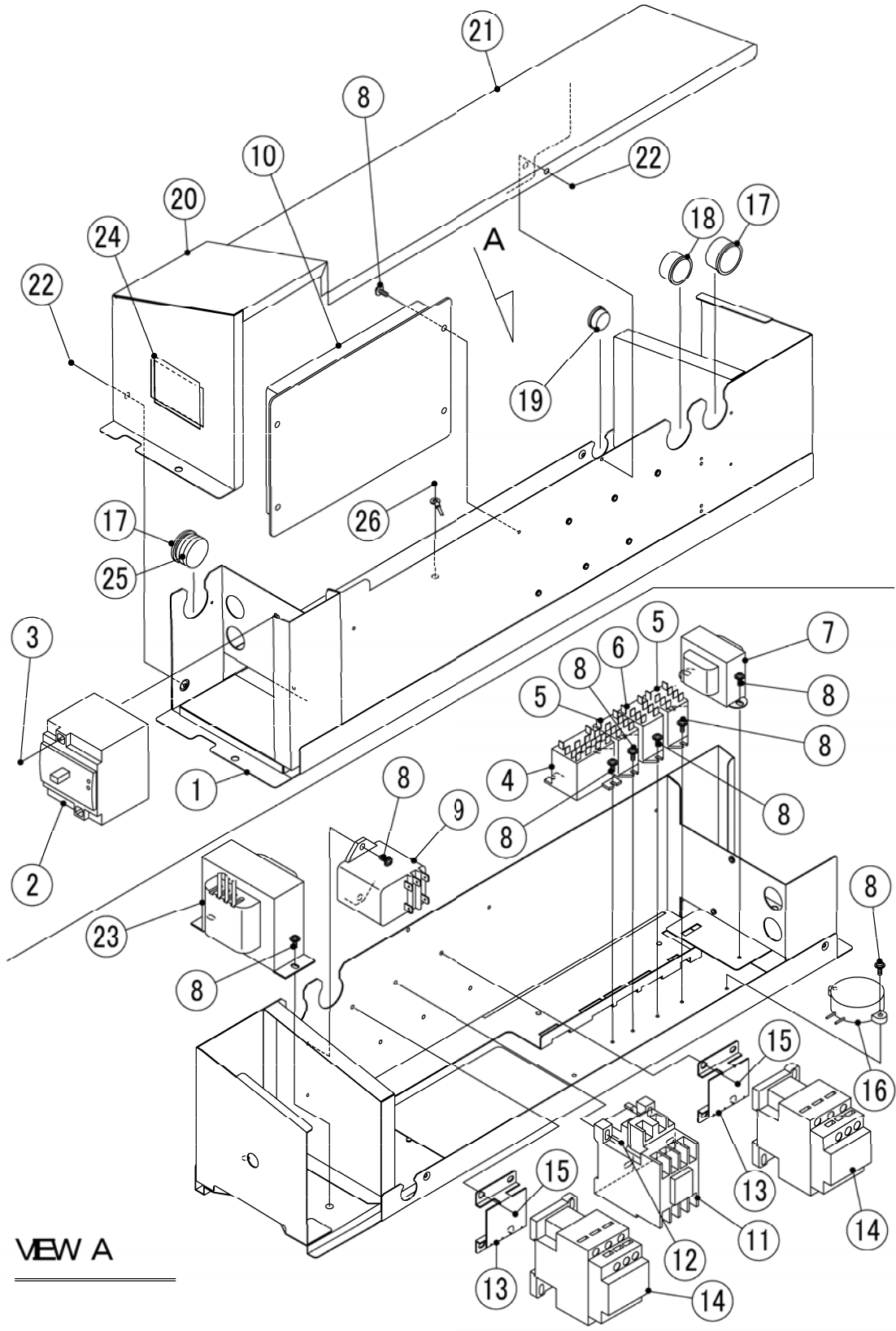

VIEW A

HA

MODEL : <b>JWE-620UA-6B</b>				TITLE : <b>L. CONTROL BOX ASSY</b>			
INDEX NO.	DESCRIPTION	MATERIAL OR MODEL NUMBER	PART NUMBER	REQ'D NUMBER			
				U-1,U-2 U-3,V-0 A-0	A-1,B-0 B-1	B-2	B-3
1	CONTROL BOX	G.S	2H9529G01	1	1	1	1
2	BREAKER - GFCI	NV100-FHU	P01006-01	1	1	1	1
3	PAN HEAD MACHINE SCREW(SPRING WASHER & SMALL FLAT WASHER)	S.S	FSM0455F0	2	2	2	2
4	RELAY (B)	LY-4F	406133-02	1	1	1	1
5	RELAY	LY-1F	418271-02	1	2	2	2
6	RELAY	LY-2ZF	406132-05	1	1	1	1
7	TRANSFORMER	-	P01763-01	1	1	1	1
8	TP TAPPING SCREW	-	431415-01	11	12	12	12
9	RELAY - PHASE REVERSAL	RDR-S230-M	P01000-01	1	1	1	1
10	CONTROLLER BOARD	-	P00998-01	1	1	1	1
11	MAGNETIC CONTACTOR	S-N11	4Y3365-01	1	1	1	1
12	TRUSS HEAD MACHINE SCREW	S.S	FST0416S0	2	2	2	2
13	BASE	IBTJD09	462804-01	2	2	2	2
14	MAGNETIC CONTACTOR	LC1D186L7-HS	4Y2392-02	2	2	2	2
15	TRUSS HEAD MACHINE SCREW	S.S	FST0408S0	4	4	4	4
16	BUZZER	PKB5-3A24-ASSY	463024-01	1	1	1	1
17	BUSHING		428394-05	2	2	2	2
18	BUSHING		428394-04	1	1	1	1
19	BUSHING		428394-02	1	1	1	1
20	COVER (A) - CONTROL BOX	G.S	3Y4239M01	1	1	1	1
21	COVER (B) - CONTROL BOX	G.S	3Y4240M01	1	1	1	1
22	TRUSS HEAD MACHINE SCREW	S.S	FST0408S0	5	5	5	5
23	TRANSFORMER	HO4109-000	P01004-01	1	1	1	1
24	SHEET (C) -ELB	PVC	4Y5403P03	1	1	1	1
25	CABLE TIE	PA, CV-150A	7920-0021	1	1	1	1
26	TRUSS HEAD MACHINE SCREW (S-TITE)	S.S	FTS0406M0	1	1	1	1

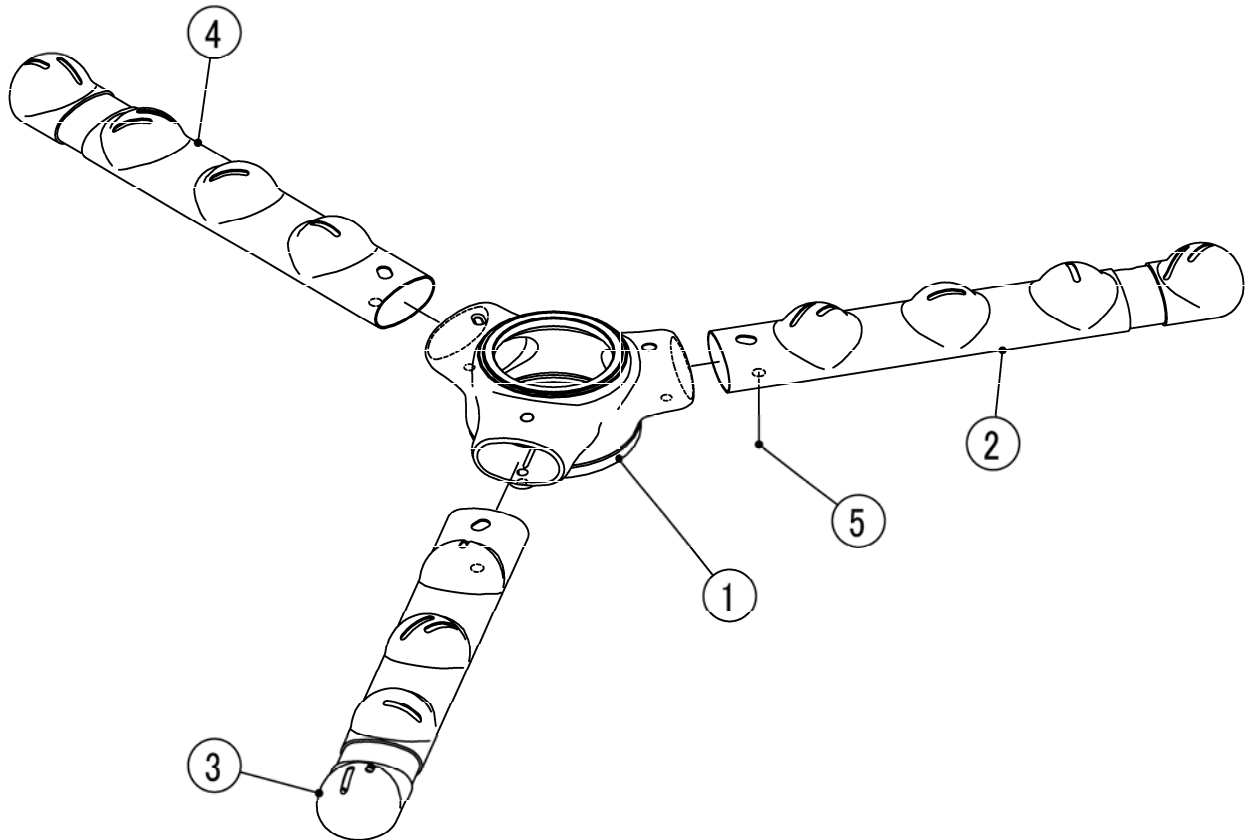

**HA**

MODEL : <b>JWE-620UA-6B</b>		TITLE : <b>M. SPRAY ARM ASSY</b>					
INDEX NO.	DESCRIPTION	MATERIAL OR MODEL NUMBER	PART NUMBER	REQ'D NUMBER			
				U-1,U-2 U-3,V-0 A-0	A-1,B-0 B-1	B-2	B-3
1	SPRAY HOLDER	PPS, PE	4Y6098A01	1	1	1	1
2	SPRAY ARM PIPE (LO) - (A)	S.S	3Y0427-01	× 1			
			3Y5027G01	○1	1	1	1
3	SPRAY ARM PIPE (B)	S.S	3Y0549-02	× 1			
			3Y5027G03	○1	1	1	1
4	SPRAY ARM PIPE (C)	S.S	3Y0550-02	× 1			
			3Y5027G05	○1	1	1	1
5	HEX HEAD BOLT W/ WASHERS	S.S	FBK0412S1	3	3	3	3

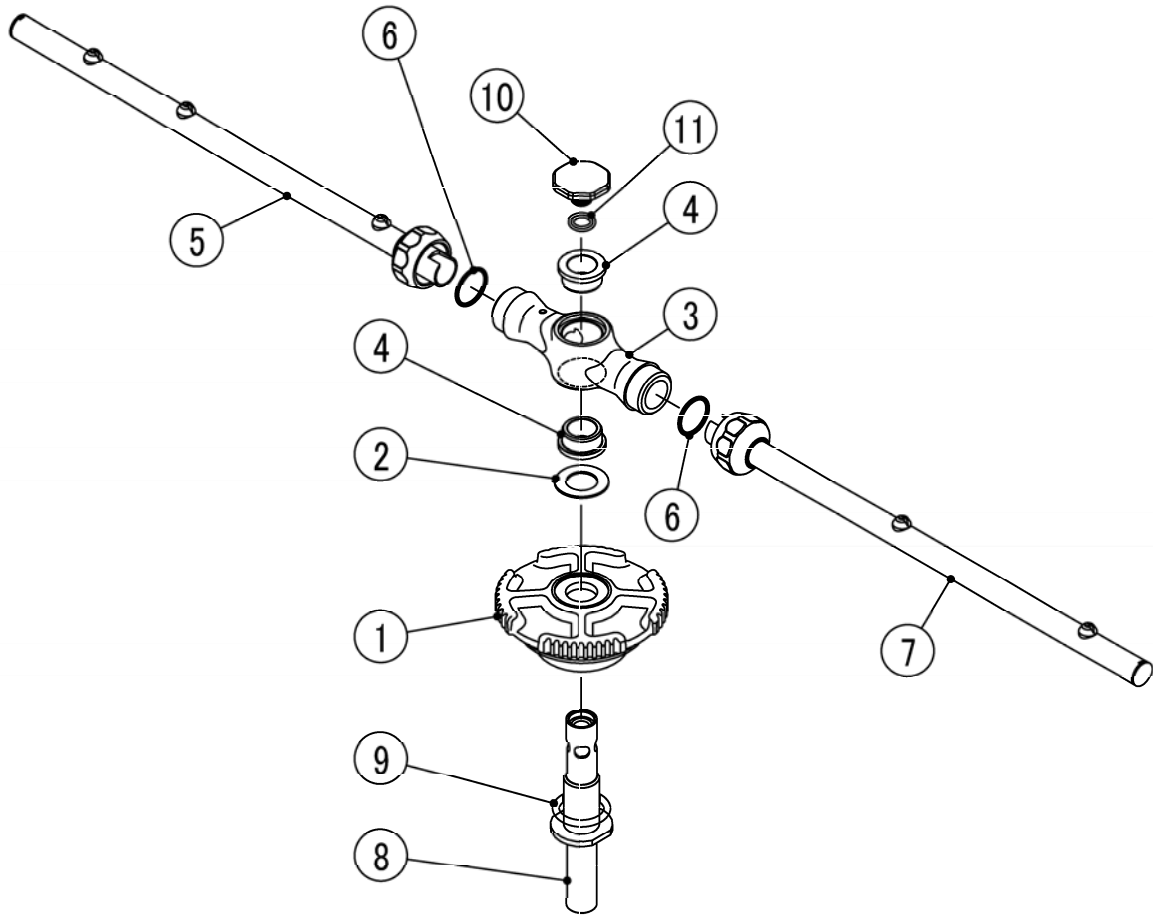



**HA**

MODEL : <b>JWE-620UA-6B</b>				TITLE : <b>N. RINSE SPRAY ARM (LO) ASSY</b>			
INDEX NO.	DESCRIPTION	MATERIAL OR MODEL NUMBER	PART NUMBER	REQ'D NUMBER			
				U-1,U-2 U-3,V-0 A-0	A-1,B-0 B-1	B-2	B-3
1	SPRAY ARM NUT (LO)	PPS, S.S	4Y5307A01	1	1	1	1
2	WASHER - RINSE HOLDER	S.S	4Y3204-01	1	1	1	1
3	RINSE HOLDER	PPS	3Y0450-01	1	1	1	1
4	SLEEVE BEARING	PPS	4Y3237-03	2	2	2	2
5	RINSE SPRAY ARM (A) - LO	S.S	3Y0407G02	×1			
			3Y3593G02	○1	1	1	1
6	O-RING	EPDM P12	7614-P012	2	2	2	2
7	RINSE SPRAY ARM (B) - LO	S.S	3Y0410G02	×1			
			3Y3594G02	○1	1	1	1
8	RINSE SHAFT (LO)	S.S	3Y6774M01	1	1	1	-
			3Y2449M01				1
9	O-RING	NBR P14	7611-P014	1	1	1	1
10	BOLT - RINSE SHAFT	S.S	4Y3206-01	1	1	1	1
11	O-RING	EPDM P7	7614-P007	1	1	1	1

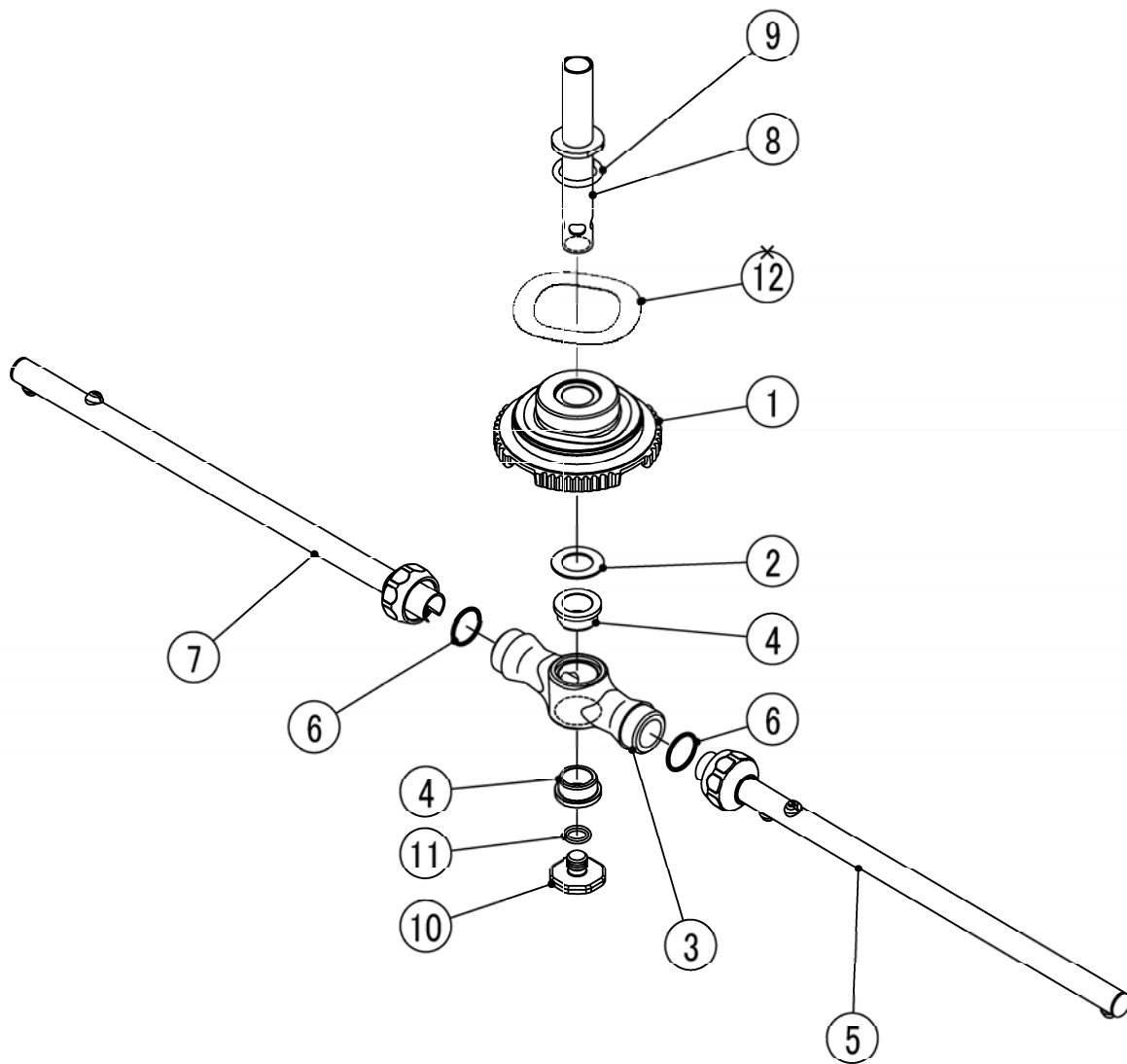

**HA**

MODEL : <b>JWE-620UA-6B</b>		TITLE : <b>P. RINSE SPRAY ARM (UP) ASSY</b>					
INDEX NO.	DESCRIPTION	MATERIAL OR MODEL NUMBER	PART NUMBER	REQ'D NUMBER			
				U-1,U-2 U-3,V-0 A-0	A-1,B-0 B-1	B-2	B-3
1	SPRAY ARM NUT (UP)		4Y7865A01	1	1	-	
		PPS, S.S	4Y3555A01			1	1
2	WASHER - RINSE HOLDER	S.S	4Y3204-01	1	1	1	1
3	RINSE HOLDER	PPS	3Y0450-01	1	1	1	1
4	SLEEVE BEARING	PPS	4Y3237-03	2	2	2	2
5	RINSE SPRAY ARM (A) - UP	S.S	3Y0413G02	×1			
			3Y3591G02	○1	1	1	1
6	O-RING	EPDM P12	7614-P012	2	2	2	2
7	RINSE SPRAY ARM (B) - UP	S.S	3Y0416G02	×1			
			3Y3592G02	○1	1	1	1
8	RINSE SHAFT (UP)	S.S	3Y6773M01	1	1	1	-
			3Y2450M01				1
9	O-RING	NBR P12	7611-P012	1	1	1	1
10	BOLT - RINSE SHAFT	S.S	4Y3206-01	1	1	1	1
11	O-RING	EPDM P7	7614-P007	1	1	1	1
12	WAVE WASHER		4Y3207-01	1	1	-	

Q. OVERFLOW PIPE ASSY

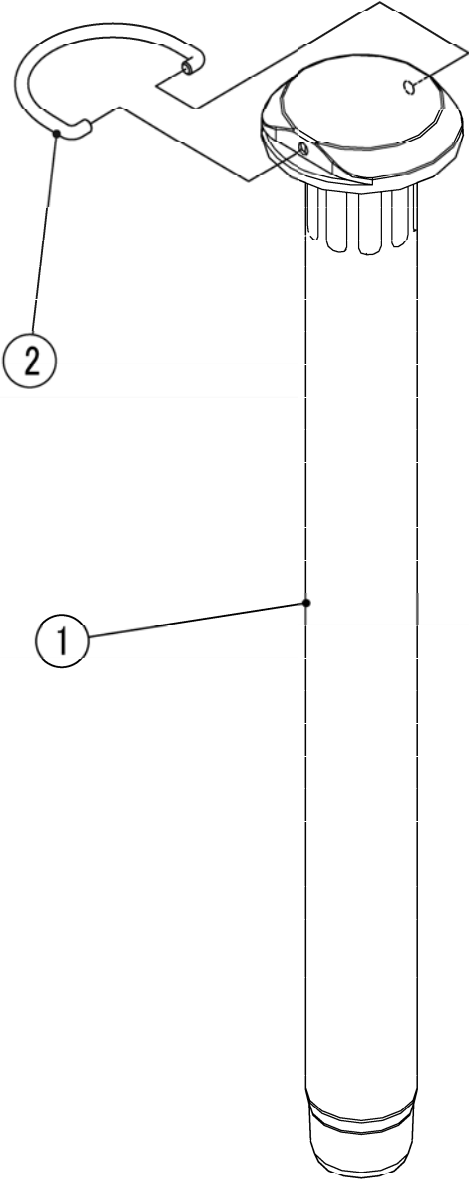

HA

MODEL : JWE-620UA-6B		TITLE : Q. OVERFLOW PIPE ASSY					
INDEX NO.	DESCRIPTION	MATERIAL OR MODEL NUMBER	PART NUMBER	REQ'D NUMBER			
				U-1,U-2 U-3,V-0 A-0	A-1,B-0 B-1	B-2	B-3
1	OVERFLOW PIPE	S.S	3Y6604G01	1	1	1	1
2	HANDLE - OF	S.S	4Y3160-01	1	1	1	1

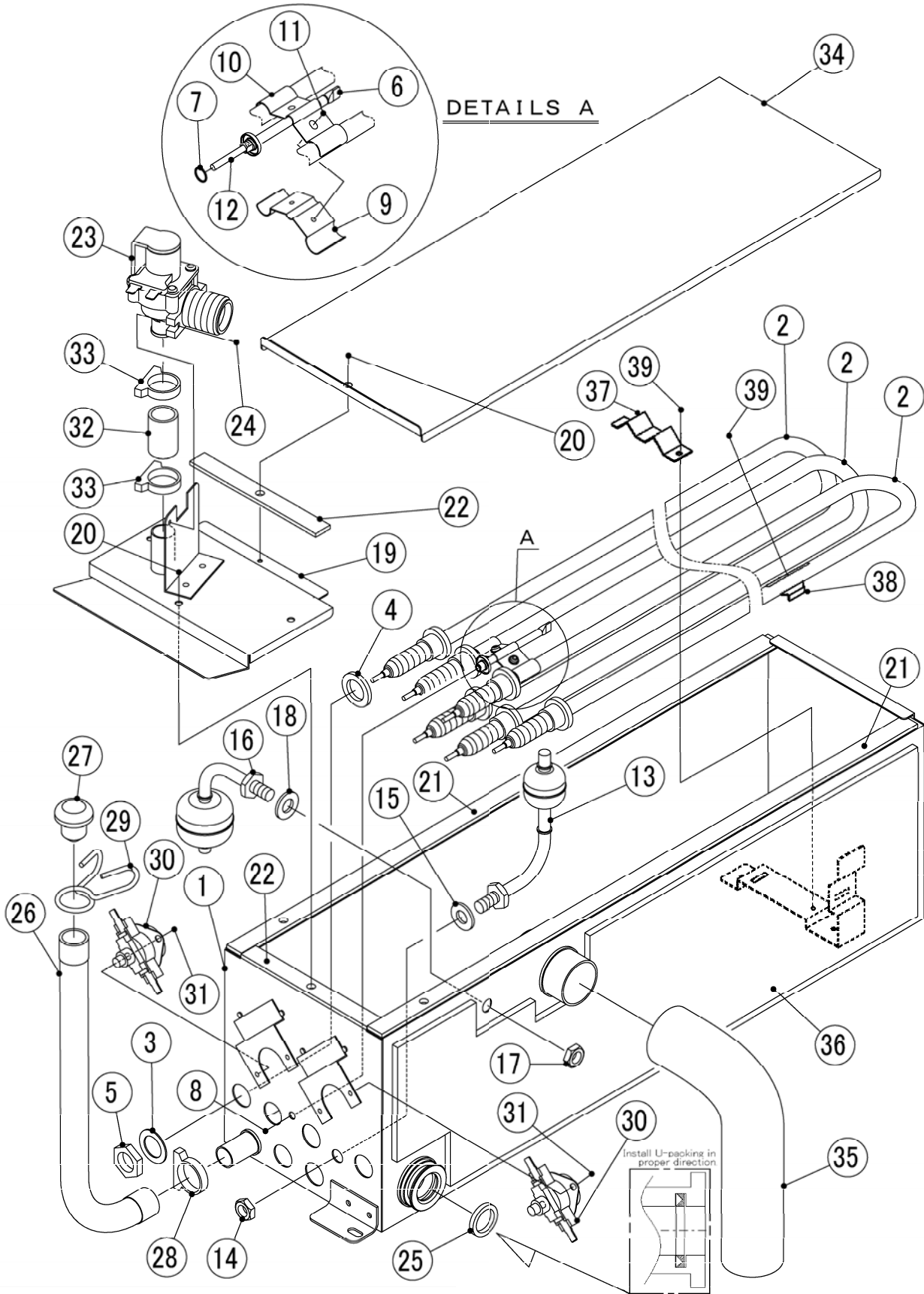

HA

MODEL : JWE-620UA-6B		TITLE : R. RINSE TANK ASSY					
INDEX NO.	DESCRIPTION	MATERIAL OR MODEL NUMBER	PART NUMBER	REQ'D NUMBER			
				U-1,U-2 U-3,V-0 A-0	A-1,B-0 B-1	B-2	B-3
1	RINSE TANK - WELD	S.S	2H9676G01	1	1	1	1
2	SHEATH HEATER	-	P00551-01	3	3	3	3
3	WASHER	S.S	P00551F01	6	6	6	6
4	PACKING	SI.R	P00551F02	6	6	6	6
5	NUT	S.S	P00551F03	6	6	6	6
6	THERMISTOR PIPE - WELD	S.S	4Y3183G01	1	1	1	1
7	O-RING	NBR P7	7611-P007	1	1	1	1
8	NUT	S.S	FNH106S0	1	1	1	1
9	THERMOSTAT PLATE (LO)	S.S	4Y3163-01	1	1	1	1
10	THERMOSTAT PLATE (UP)	S.S	4Y3164-01	1	1	1	1
11	PAN HEAD MACHINE SCREW W/ WASHERS	S.S	FSK0308S0	2	2	2	2
12	THERMISTOR (B) - ASSY	-	449759-01	1	1	1	1
13	FLOAT SWITCH	-	449401-01	1	1	1	1
14	NUT	-	449401F01	1	1	1	1
15	PACKING	SI.R	449401F02	1	1	1	1
16	FLOAT SWITCH	-	4Y2820-01	1	1	1	1
17	NUT	-	4Y2820F01	1	1	1	1
18	PACKING	SI.R	4Y2820F02	1	1	1	1
19	COVER (B) - RINSE TANK	S.S	4Y3659G01	1	1	1	1
20	TRUSS HEAD TAPPING SCREW	S.S	FT20408S0	4	4	4	4
21	PACKING (A)	SI.R	4Y3636-01	2	2	2	2
22	PACKING (B)	SI.R	4Y3637-01	2	2	2	2
23	WATER VALVE	-	456461-01	1	1	1	1
24	TRUSS HEAD MACHINE SCREW	S.S	FST0410S0	1	1	1	1
25	U-PACKING	EPDM	4Y3371-03	1	1	1	1
26	HOSE - RESERVOIR	EPDM	4Y4097R01	1	1	1	1
27	CAP (A)	EPDM	4X3337-01	1	1	1	1
28	HOSE CLAMP	PA66	P00728-02	1	1	1	1
29	HOSE BAND	-	427443-06	1	1	1	1
30	THERMOSTAT	-	4Y1929-02	2	2	2	2
31	PAN HEAD MACHINE SCREW W/ WASHERS	S.S	FSK0408S0	4	4	4	4
32	HOSE - WV	SI.R	4Y3492-01	1	1	1	1





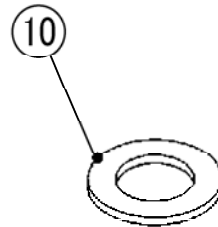
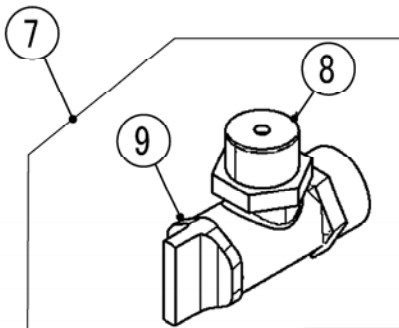
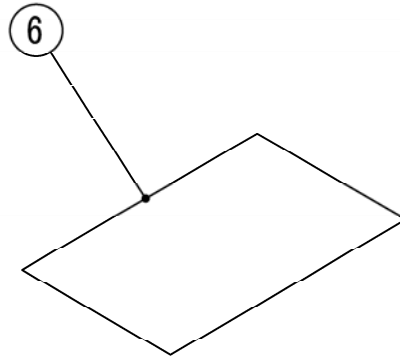
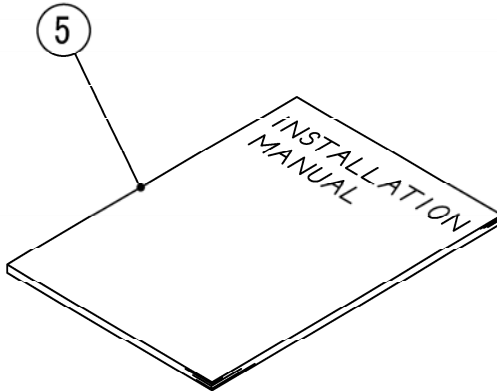
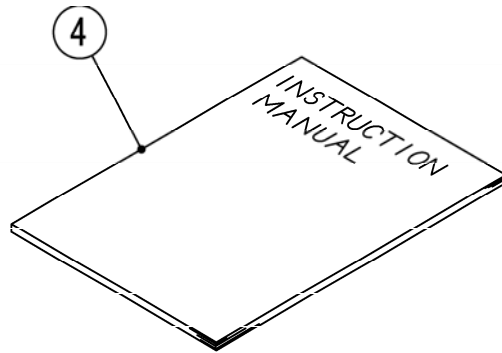
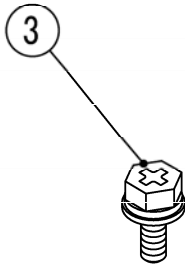
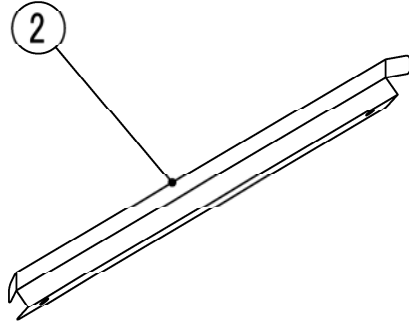
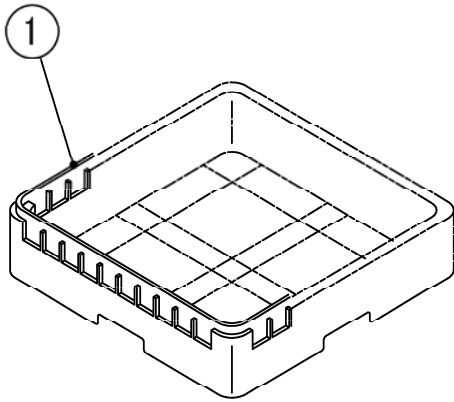

HA

MODEL : <b>JWE-620UA-6B</b>				TITLE : <b>S. ACCESSORIES</b>			
INDEX NO.	DESCRIPTION	MATERIAL OR MODEL NUMBER	PART NUMBER	REQ'D NUMBER			
				U-1,U-2 U-3,V-0 A-0	A-1,B-0 B-1	B-2	B-3
1	RACK	PP	1H0790-01	1	1	1	1
2	PLATE - RACK GUIDE	S.S	3Y0402-01	1	1	1	1
3	HEX HEAD BOLT W/ WASHERS	SS	FBK0512S1	2	2	2	2
4	INSTRUCTION MANUAL	-	9180VC10B	1	1	1	1
5	INSTALLATION MANUAL	-	9280VC10B	1	1	1	1
6	MAINTENANCE SHEET	-	255513L01	1	1	1	1
7	STRAINER ASSY (INCLUDES ITEMS 8 and 9)	-	4Y5376A01	1	1	1	1
8	STRAINER BODY	-	3Y3522M01	1	1	1	1
9	FILTER	-	442086F01	1	1	1	1
10	PACKING	-	442089-02	1	1	1	1